

Operating Instructions

OBSERVE ALL 'HAZARDOUS PLANT' SAFETY PROCEDURES. AT ALL TIMES ENSURE THAT OTHER SITE PERSONNEL STAY OUT OF WORKING AREA OF MACHINE.

TO ENGAGE IMPLEMENT:

1. Bottom out (fully extend) Bucket cylinder, turn key switch to "OFF", cabin alarms will be activated, and Wedge will be retracted.
2. Engage 'hook' end of Hitch to front pin of Implement, then proceed to lift Implement whilst simultaneously (by extending the Bucket cylinder) turning the Hitch and Implement until the 'hook' end of the Hitch is pointing upwards and the Implements rear in bears against the 'wedge' end of the Hitch, continue extending the Bucket cylinder until it has bottomed out ensuring that the Implements front pin is fully nested in the hook. See fig. 1, 2, 3 & 4 below.
3. Turn key switch to 'ON', cabin alarms will be de-activated, and the Wedge will be driven home to fully engage the Implement.
4. Check that the Implement is properly engaged by trying to remove it by force.
5. Remove key from switch and place in its designated storage location.

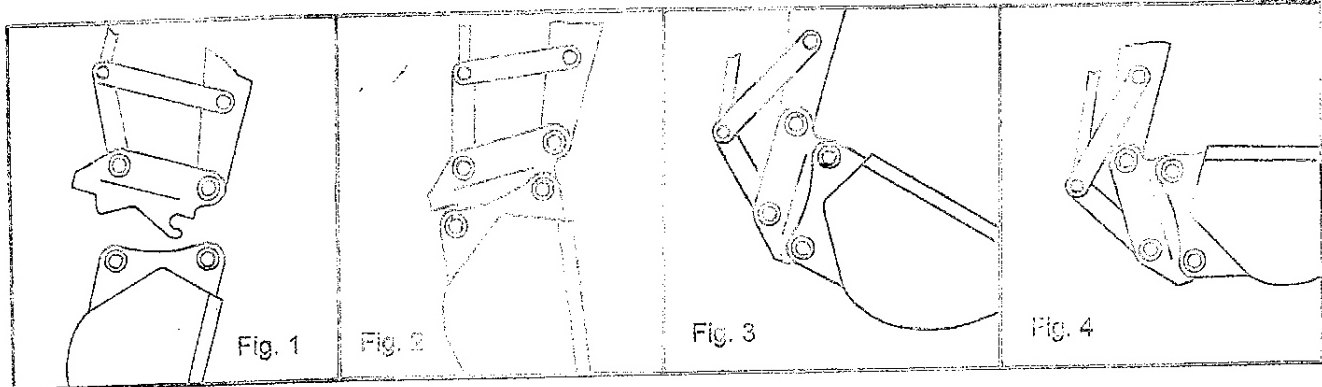

TO RELEASE HITCH IMPLEMENT

1. With the Bucket cylinder bottomed out, bring Implement to within a few inches of ground, turn key switch to 'OFF', cabin alarms will be activated and Wedge will be retracted.
2. Slowly retract Bucket cylinder, the Implement will then disengage and drop to the ground. If you are not immediately picking up another Implement, turn key switch to 'ON' to extinguish and silence cabin alarms.

6. Exit the cabin and physically drop the independent latching device into the Essex Lock-Hitch[®] being sure to secure the lynch pin through the device.

ESSEX ENGINEERING PTY LTD
CONTACT: STUART ESSEX AND STAFF
11 Glastonbury Avenue
UNANDERRA NSW 2526

Phone: 02 4274 2000
Fax: 02 4274 2000
Email: info@bigpond.com

© 2000 Essex Engineering Pty Ltd